

PAGE	
1	Cover Page
2-3	INDEX/CONTENTS
New Generation Machining Center	
4	New Generation Machining Center
5	Transmission System
6	Structure
7	Linear guideway
8	Oil/Coolant Separator, Spindle coolant Cooling
9	Spindle Unit
10	Spindle Specification and Performance
12	Direct Drive Spindle
13	Tool Changing System -ATC
Chip Removal System	
14	Highly Efficient Chip Removal Mechanism
Control System	
15	Controller
16-17	Meet Customer Requirements
Operation	
18-19	User-friendly, Accessibility, Maintainability
20	Convenience
21	Cooling System
22-23	High Performance Configuration
24	Safety Door
Machine Precision	
25	Machine Equipped Measuring Devices
26	Advanced Inspection Equipment and Technology
27	Machining Performance
Production and Workshop	
28	Production Management and Network Service
29	Workshop Environment and Floor Area
Equipment Specification	
30-31	Outline Dimensions
32	Machine Specifications
33	Equipment List

Production Site



ATC System



Measurement System



Maintenance



Transmission System



Structure 1

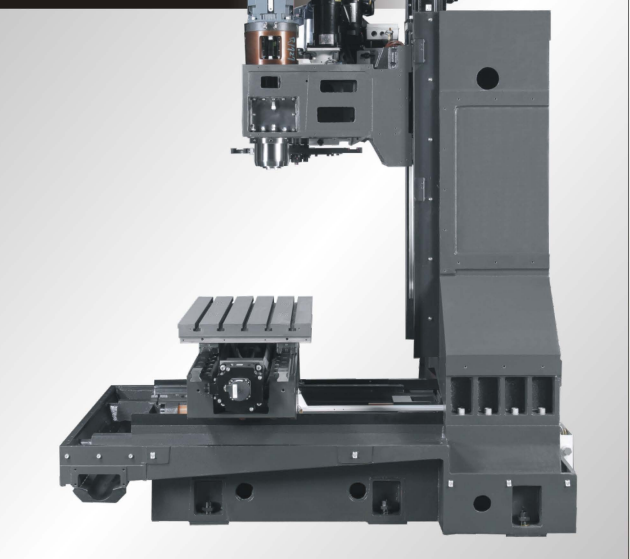

Controller System



Structure 2

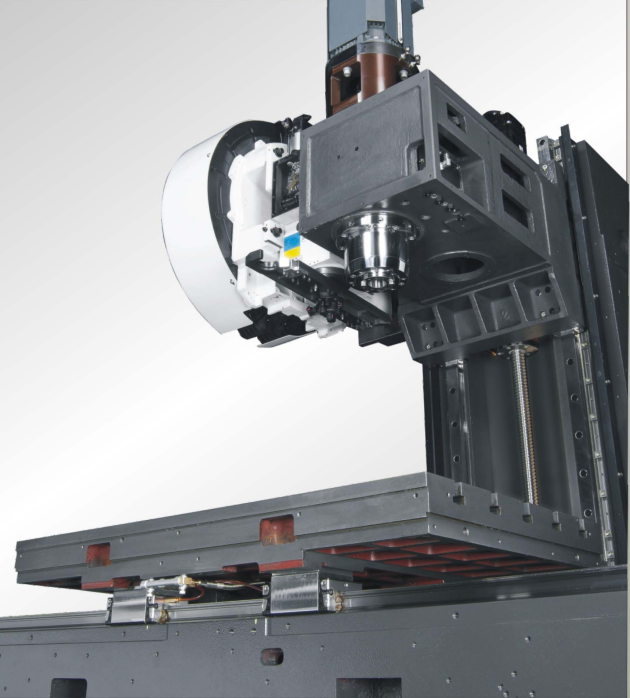

Spindle System



3-axes linear scale

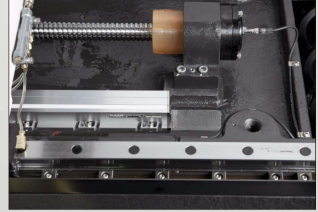

4th axis



Machining Application

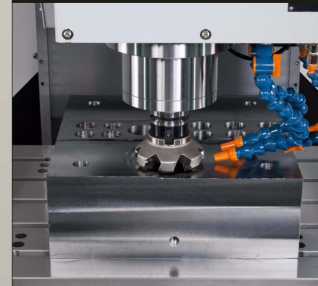

Chip Removal System

